



APPLICATION FOR KENNEL LICENCE

Rotorua Lakes Council is the operating name of Rotorua District Council

IMPORTANT INFORMATION

1. No dog owner shall keep or allow to be kept more than two (2) dogs of a greater age than three months for any period exceeding thirty (30) days on any premises within the urban fence.
2. The application shall attempt to obtain the four closest neighbours’ signatures prior to submitting this application. [see attached sheet].
3. The site/location must be checked by an Animal Control Officer prior to any building being commenced.
4. An application fee of \$77.20 must be paid before any inspection is carried out.
5. A yearly fee of \$38.85 is required to be paid on the 1st day of July for a Renewal of Licence.

1. APPLICANTS INFORMATION

I [full name] _____
 Of [address] _____
 Phone: _____

Hereby apply for a licence to keep three or more dogs over the age of three [3] months, pursuant to Clause 11 of the Rotorua Lakes Council Dog Control Bylaw 2005.

I enclose the application fee of \$ _____ Signed: _____
 Date: _____

2. DESCRIPTION OF DOGS

NAME	BREED	SEX	TAG NO.

Are these dogs [tick one] House Dogs: Kept in Kennels:

3. OFFICE USE ONLY

AMOUNT: \$ _____	DATE PAID: _____	RECEIPT No.: _____
------------------	------------------	--------------------

4. NEIGHBOURS CONSENT FORM

I **agree** to the above named person keeping on his / her property in pens and/or kennels, dogs/bitches/spayed bitches to the breed(s) and numbers noted on page 1:

1.

Full Name: _____

Address: _____

Date _____ Signature: _____

2.

Full Name: _____

Address: _____

Date _____ Signature: _____

3.

Full Name: _____

Address: _____

Date _____ Signature: _____

4.

Full Name: _____

Address: _____

Date _____ Signature: _____

5. DOG KENNEL STANDARDS

The following sets out the minimum standards of housing in cases of applications to keep three or more dogs: [refer to attached standard drawing for pre-treatment of dog kennels not connected to Council's Sewerage System]

1. Kennels are not to be sited closer than 6 metres to a neighbouring residential building and 1 metre from any boundary of the applicant's property.
2. If a permanent as opposed to a moveable kennel and run is to be constructed the base area of the run must be concreted to an approved standard with a concrete nib wall around the base of the concrete pad no less than 200mm in height with adequate falls to a gully trap.
3. A water supply must be available in order to facilitate cleaning and the supply of fresh drinking water.
4. The entire kennel requires to be maintained in a sanitary condition at all times.
5. Dogs may be housed other than in outdoor kennels, having regard to the individual circumstances of each case, subject to any condition that may be imposed.
6. A building consent will be required for structures over 10 square metres.

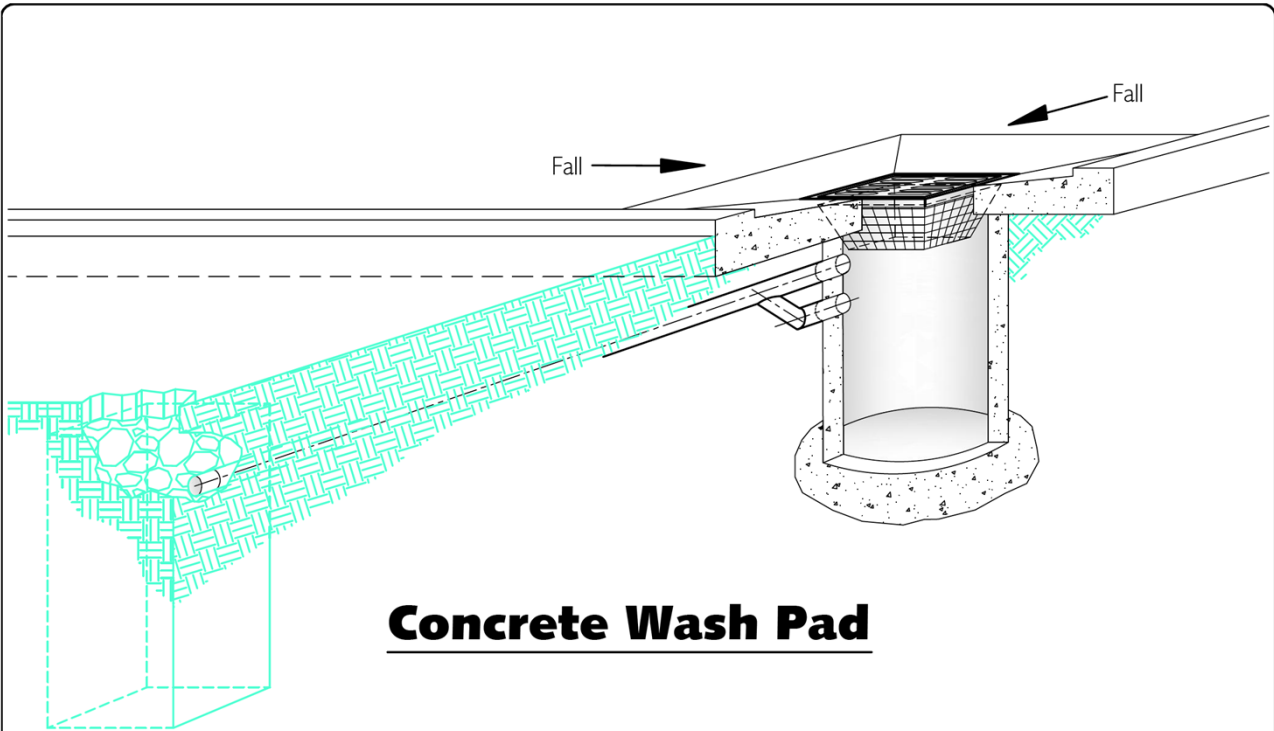

Concrete Wash Pad

Section through Dog's Wash Pad

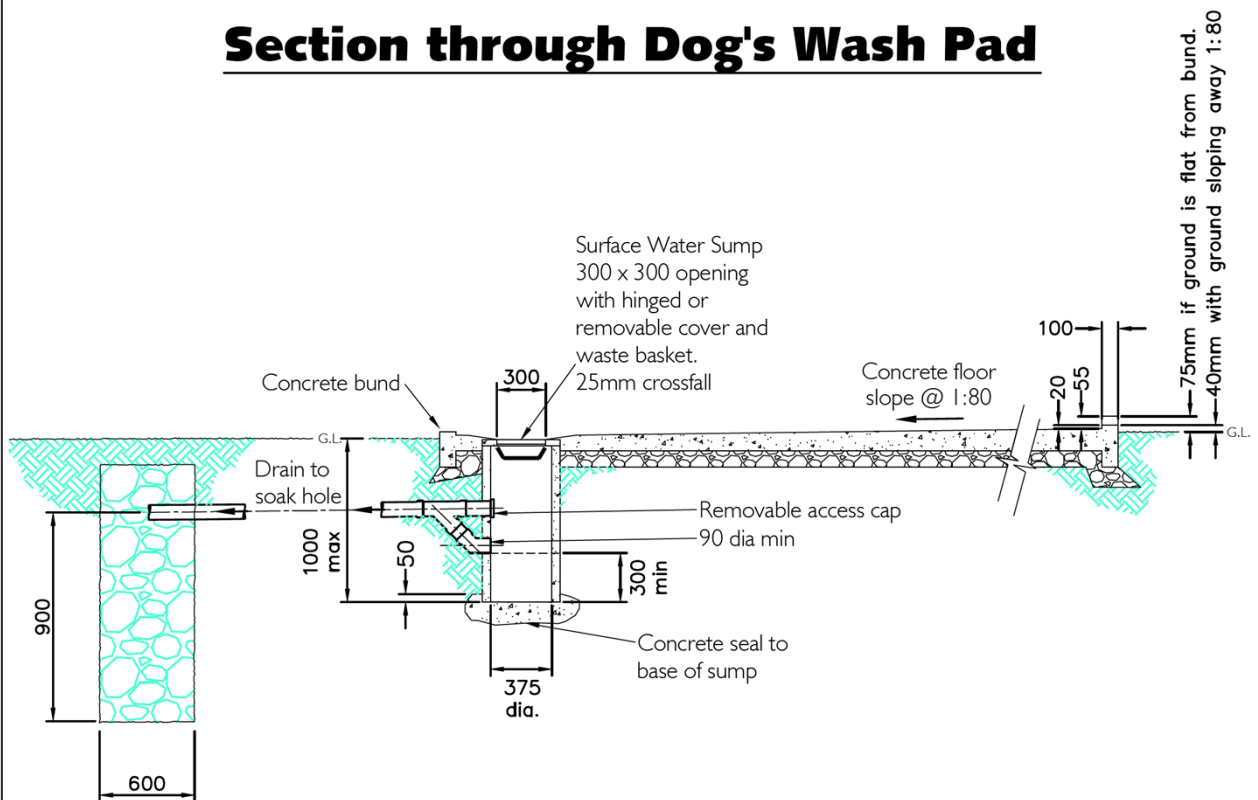

STANDARD DRAWING- SANITARY SEWERAGE		NEW DATA
ROTORUA LAKES COUNCIL	PRE-TREATMENT FOR DOG KENNELS	
	Not connected to Councils Sewerage System	
ROTORUA CIVIL ENGINEERING INDUSTRY STANDARD		SS 12832-001 NOT TO SCALE